

Single-in-Line SIL/SIP Reed Relays

Up to 20 Watts switching for Dry Reed Relays

Up to 50 Watts switching for Mercury Reed Relays

Features

- **SoftCenter®** construction (see adjacent diagram)
- Highest quality instrumentation grade switches
- Encapsulated in a Plastic package with internal mu-metal magnetic screen
- Wide range of switch configurations - 1 Form A, 1 Form B, 2 Form A, 1 Form C
- Two pole relay requires the same board area as the single pole type
- Dry and mercury wetted switches are available with the same pin configuration and footprint. (see "A useful tip" below)
- Insulation resistance greater than $10^{12} \Omega$ for dry Form A devices
- 3, 5, 12 and 24 Volt coils with or without internal diode
- 100% tested for dynamic contact resistance for guaranteed performance

The Series 105 is a range of Single-in Line reed relays, available with a wide variety of switching configurations and switch types, including mercury wetted versions. They feature internal mu-metal magnetic screens which allow high packing density without the risk of magnetic interaction problems.

The Pickering Series 100, 101, 103, 106, 107 and 108 all have the same pin locations as the Series 105. If a reduced coil power is desired, please consider our Series 100 and 101 which may be driven directly from CMOS logic. If a higher packing density is required, smaller devices are available in other Pickering SIL ranges.

In addition to the relays shown on this brochure, many other special types are manufactured to meet customers specific requirements. Please contact our technical sales department for further information or samples.

A useful tip

If there is a chance that you might want to use mercury wetted relays instead of dry relays at a later date, for example to increase switch ratings, lay out the PCB initially as though for the mercury wetted type with pin 1 uppermost. This allows upgrading later without PCB changes. The mercury versions in the Series 105 have identical pin configurations to the dry types.

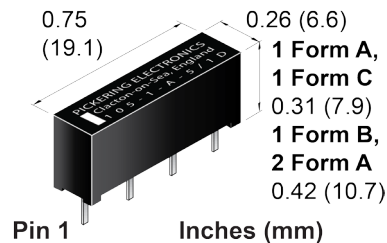
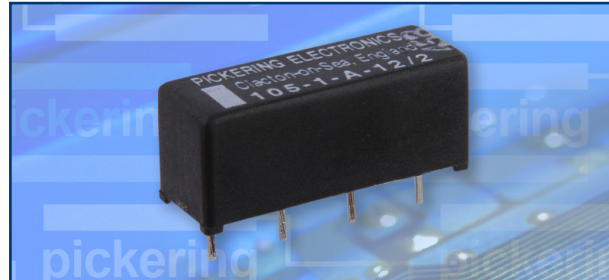

Switch Ratings - Dry switches

- Single or Double pole Form A (Energize to Make) relays. Up to 1 Amp switching at 20 Watts
- Single pole Form B (Energize to Break) relays. Up to 1 Amp switching at 20 Watts
- Single pole Form C (Change-over) relays. 0.25 Amps switching at 3 Watts

Switch Ratings - Mercury Wetted Switches

- Single or Double pole Form A (Energize to Make) relays. 2 Amp switching at 50 Watts
- Single pole, Non Position Sensitive, Form A (Energize to Make) relays. 2 Amp switching at 50 Watts

Typical Pickering **SoftCenter®** Construction

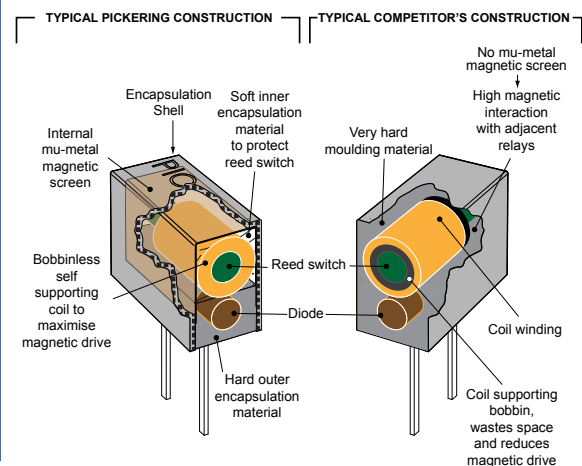

Series 105 switch ratings - The contact ratings for each switch type are shown below:

Switch No	Switch form	Power rating	Max. switch current	Max. carry current	Max. switching volts	Life expectancy ops typical (see Note ¹ below)	Operate time inc bounce (max)	Release time	Special features
1	A or B	15 W (5 V Versions) 20 W (12 & 24 V)	1.0 A	1.2 A	200	10E9	0.5 ms	0.2 ms	General purpose
2	A	10 W	0.5 A	1.2 A	200	10E9	0.5 ms	0.2 ms	Low level
3	C	3 W	0.25 A	1.2 A	200	10E7	1.0 ms	0.5 ms	Change over
4	A	10 W	0.5 A	1.2 A	400	10E7	0.75 ms	0.5 ms	500V stand-off

Switch no.2 is particularly good for switching low currents and/or voltages. It is the ideal switch for A.T.E. systems where cold switching techniques are often used. Where higher power levels are involved, switch no.1 is more suitable.

Dry Relay - Coil data and type numbers

Device type	Type Number	Coil (V)	Coil resistance	Max. contact resistance (initial)	Insulation resistance (minimum)		Capacitance (typical) (see Note ² below)	
					Switch to coil	Across switch	Closed switch to coil	Across open switch
1 Form A (energize to make) General Purpose Switch No. 1	105-1-A-5/1D	5	500 Ω	0.15 Ω	10E12 Ω	10E12 Ω	2.5 pF	0.1 pF
	105-1-A-12/1D	12	1000 Ω					
	105-1-A-24/1D	24	3000 Ω					
1 Form A (energize to make) Low Level Switch No. 2	105-1-A-3/2D	3	500 Ω	0.12 Ω	10E12 Ω	10E12 Ω	2.5 pF	0.1 pF
	105-1-A-5/2D	5	500 Ω					
	105-1-A-12/2D	12	1000 Ω					
1 Form A (energize to make) High Voltage Switch No. 4	105-1-A-3/4D	5	500 Ω	0.15 Ω	10E12 Ω	10E12 Ω	2.5 pF	0.15 pF
	105-1-A-12/4D	12	1000 Ω					
	105-1-A-24/4D	24	3000 Ω					
1 Form C (change-over) Switch No. 3	105-1-C-5/3D	5	500 Ω	0.20 Ω	10E12 Ω	10E10 Ω	See Note ³	See Note ³
	105-1-C-12/3D	12	1000 Ω					
	105-1-C-24/3D	24	3000 Ω					
1 Form B (energize to break) General Purpose Switch No. 1	105-1-B-5/1D	5	1000 Ω	0.15 Ω	10E12 Ω	10E12 Ω	2.5 pF	0.1 pF
	105-1-B-12/1D	12	3000 Ω					
	105-1-B-24/1D	24	3000 Ω					
2 Form A (energize to make) General Purpose Switch No. 1	105-2-A-5/1D	5	500 Ω	0.17 Ω	10E12 Ω	10E12 Ω	See Note ³	See Note ³
	105-2-A-12/1D	12	1000 Ω					
	105-2-A-24/1D	24	3000 Ω					
2 Form A (energize to make) Low Level Switch No. 2	105-2-A-5/2D	5	500 Ω	0.15 Ω	10E12 Ω	10E12 Ω	See Note ³	See Note ³
	105-2-A-12/2D	12	1000 Ω					
	105-2-A-24/2D	24	3000 Ω					

When an internal diode is required, the suffix D is added to the part number as shown in the table.

Mercury Reed: Series 105 switch ratings - The contact ratings for each switch type are shown below:

Switch No	Switch form	Power rating	Max. switch current	Max. carry current	Max. switching volts	Life expectancy ops typical (see Note ¹ below)	Operate time (max)	Release time	Special features
6	A	50 W	2 A	3 A	500	10E8	1.5 ms	1.0 ms	Standard Mercury
8	A	50 W	2 A	2 A	350	10E8	1.5 ms	1.0 ms	Position Insensitive

Mercury Relay: Coil data and type numbers

Device type	Type Number	Coil (V)	Coil resistance	Max. contact resistance (initial)	Insulation resistance (minimum)		Capacitance (typical) (see Note ² below)	
					Switch to coil	Across switch	Closed switch to coil	Across open switch
1 Form A (energize to make) Switch No. 6	105-1-A-5/6D	5	140 Ω	0.075 Ω	10E12 Ω	10E11 Ω	4 pF	0.1 pF
	105-1-A-12/6D	12	500 Ω					
	105-1-A-24/6D	24	1500 Ω					
1 Form A (energize to make) Position Insensitive Switch No. 8	105-1-A-5/8D	5	140 Ω	0.100 Ω	10E12 Ω	10E11 Ω	4 pF	0.1 pF
	105-1-A-12/8D	12	500 Ω					
	105-1-A-24/8D	24	1500 Ω					
2 Form A (energize to make) Switch No. 6	105-2-A-5/6D	5	100 Ω	0.100 Ω	10E12 Ω	10E11 Ω	See Note ³	See Note ³
	105-2-A-12/6D	12	375 Ω					
	105-2-A-24/6D	24	1000 Ω					

When an internal diode is required, the suffix D is added to the part number as shown in the table.

Note¹ Life expectancy

The life of a reed relay depends upon the switch load and end of life criteria. For example, for an 'end of life' contact resistance specification of 1 Ω, switching low loads (10 V at 10 mA resistive) or when 'cold' switching, typical life is approx 1 x 10⁹ ops. At the maximum load (resistive), typical life is 1 x 10⁷ ops. In the event of abusive conditions, e.g. high currents due to capacitive inrushes, this figure reduces considerably. Pickering will be pleased to perform life testing with any particular load condition.

Note² Capacitance across open switch

The capacitance across the open switch was measured with other connections guarded.

Note³ Capacitance values

The value will depend upon on the mode of connection/guarding of unused terminals. Please contact technical sales for details.

Main contact:

UK Headquarters: email: sales@pickeringrelay.com | Tel. +44 1255 428141

Worldwide contacts:

USA: email: ussales@pickeringtest.com | Tel. +1 781 897 1710

Germany: email: desales@pickeringtest.com | Tel. +49 89 125 953 160

China: email: johnson@tomtech.cn | Tel. 0755 8374 5452

For a full list of agents and representatives visit: pickeringrelay.com/agents



ISO9001 Manufacture of Reed Relays FM 29036

Pin Configuration and Dimensional Data

Dimensions in Inches (Millimeters in brackets)

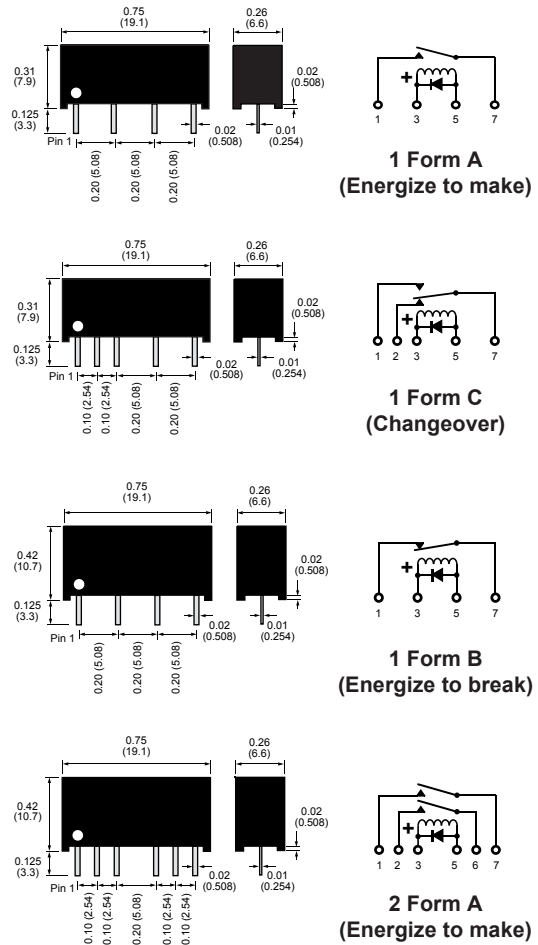

Important: Where the optional internal diode is fitted or for all Form B types, the correct coil polarity must be observed, as shown by the + symbol on the schematics.

3D Models: Interactive models of the complete range of Pickering relay products can be downloaded from the web site.

Mercury Relays

With the exception of the position insensitive type, mercury relays should be mounted vertically with pin 1 uppermost.

Internal Mu-metal Magnetic Screen

The Series 105 relays are fitted with an internal mu-metal magnetic screen which permits side-by-side stacking.

Order Code

105 - 1 - A - 5 / 2 D

Series _____
 Number of reeds _____
 Switch form _____
 Coil voltage _____
 Switch number (See table adjacent) _____
 Diode if fitted (Omit if not required) _____

Help

If you need any technical advice or other help, for example, any special tests that you would like carried out, please do not hesitate to contact our Technical Sales Department. We will always be pleased to discuss Pickering relays with you. email: techsales@pickeringrelay.com

Please ask us for a FREE evaluation sample.



pickeringrelay.com