

## Pickering Series 114

# High Power Dry SIL/SIP Reed Relays

### 40 Watts switching

## Features

- **SoftCenter®** construction (see adjacent diagram)
- Highest quality instrumentation grade switches
- Small size
- Internal mu-metal magnetic screen
- One or two switches in a single package
- Form A (energise to make) or Form B (energise to break) configurations
- 3, 5, 12 and 24 Volt coils with or without internal diode
- 100% tested for dynamic contact resistance for guaranteed performance

The Series 114 is a range of Single-In-Line reed relays intended for power levels that are beyond the capabilities of conventional dry SIL reed relays.

The more usual dry relays are rated at 0.5 amps at 10 Watts. The Series 114 have a rating of 1 amp switching at up to 40 watts and will carry 2 amps. In many cases, this higher rating will allow them to be used as an alternative to mercury wetted reed relays.

Unusually for high power relays, they feature sputtered ruthenium contacts instead of the more common electroplated rhodium or tungsten types. This makes them suitable for low level or "dry" switching also.

They are able to switch a.c. mains voltages so are suitable for interfacing to larger electromechanical relays or contactors. It is important however, to suppress back EMFs from inductive loads. This is achievable by using an RC snubber, varistor or similar voltage limiting device.

1 or 2 Form A (energise to make) or 1 Form B (energise to break) configurations are available.

The range features an internal mu-metal screen to minimize problems that would otherwise be experienced due to magnetic interaction when they are closely stacked.

Form A versions may be stacked side-by-side.

Due to the fact that the Form B types feature an internal biasing magnet, a gap of 0.4 inches minimum should be left between adjacent relays.

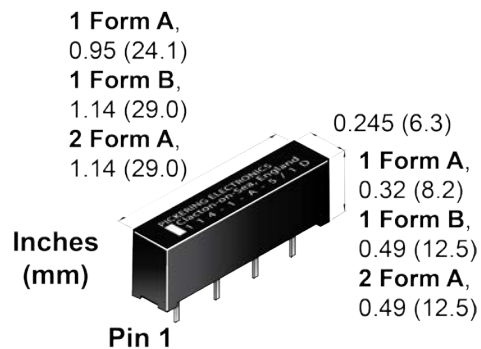
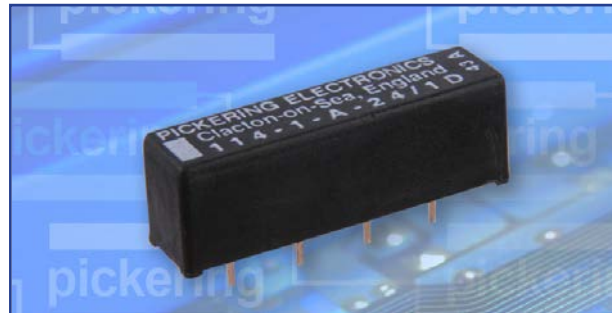

## Switch Ratings - Dry switches

- 1 Form A (Energise to Make) relays.  
200 Volts dc or 240 Volts ac rms switching at up to 40 Watts. 500 Volts dc or ac peak stand-off.
- 2 Form A (Energise to Make) relays.  
200 Volts dc or 240 Volts ac rms switching at up to 40 Watts. 500 Volts dc or ac peak stand-off
- 1 Form C (Energise to Break) relays.  
200 Volts dc or 240 Volts ac rms switching at up to 40 Watts. 500 Volts dc or ac peak stand-off

## Typical Pickering **SoftCenter®** Construction

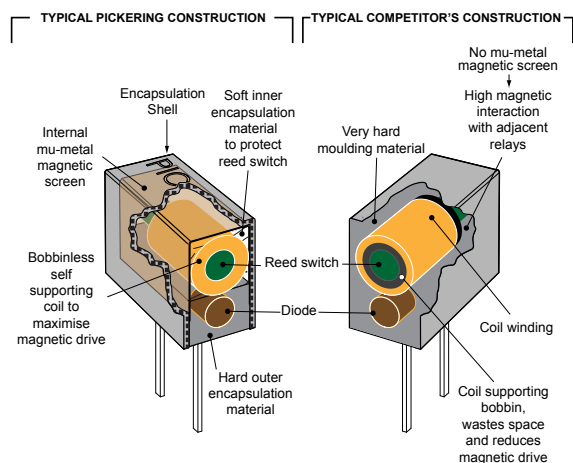

**Series 114 switch ratings** - The contact ratings for each switch type are shown below:

Switch No	Switch form	Power rating	Max. switch current	Max. carry current	Max. switching volts	Max. stand-off volts	Life expectancy ops typical (see Note <sup>1</sup> below)	Operate time inc bounce (max)	Release time	Special features
1	A or B	40 W	1.0 A	2.0 A	200 V DC 240 V AC RMS	500	10E8	1.0 ms	0.5 ms	General purpose

**Operating voltages**

Coil voltage - nominal	Must operate voltage - maximum at 25°C	Must release voltage - minimum at 25°C
3 V	2.25 V	0.3 V
5 V	3.75 V	0.5 V
12 V	9 V	1.2 V
24 V	18 V	2.4 V

**Coil data and type numbers**

Device type	Type Number	Coil (V)	Coil resistance	Max. contact resistance (initial)	Insulation resistance (minimum)		Capacitance (typical) (see Note <sup>2</sup> below)	
					Switch to coil	Across switch	Closed switch to coil	Across open switch
1 Form A (energize to make) General Purpose Switch No. 1	114-1-A-3/1D	3	75 Ω	0.15 Ω	10E12 Ω	10E12 Ω	2.0 pF	0.1 pF
	114-1-A-5/1D	5	250 Ω					
	114-1-A-12/1D	12	750 Ω					
	114-1-A-24/1D	24	2000 Ω					
2 Form A (energize to make) General Purpose Switch No. 1	114-2-A-5/1D	5	150 Ω	0.20 Ω	10E12 Ω	10E12 Ω	See Note <sup>3</sup>	See Note <sup>3</sup>
	114-2-A-12/1D	12	350 Ω					
	114-2-A-24/1D	24	1000 Ω					
1 Form B (energize to break) General Purpose Switch No. 1	114-1-B-5/1D	5	350 Ω	0.20 Ω	10E12 Ω	10E12 Ω	2.0 pF	0.1 pF
	114-1-B-12/1D	12	1000 Ω					
	114-1-B-24/1D	24	2200 Ω					

When an internal diode is required, the suffix D is added to the part number as shown in the table.

**Environmental specification**

**Standard operating temperature range:** -20 to +85 °C.

Note: The upper temperature limit can be extended to +125 °C if the coil drive voltage is increased to accommodate the resistance/temperature coefficient of the copper coil winding. This is approximately 0.4% per °C. This means that at 125 °C the coil drive voltage will need to be increased by approximately 40 x 0.4 = 16% to maintain the required magnetic drive level. Please contact sales@pickeringrelay.com for assistance if necessary.

<b>Vibration:</b> Maximum 20 G	<b>Shock:</b> Maximum 50 G
--------------------------------	----------------------------

**Note<sup>1</sup> Life expectancy**

The life of a reed relay depends upon the switch load and end of life criteria. For example, for an 'end of life' contact resistance specification of 1 Ω, switching low loads (10 V at 10 mA resistive) or when 'cold' switching, typical life is approx 100 x 10<sup>6</sup> ops. At the maximum load (resistive), typical life is 10 x 10<sup>6</sup> ops. In the event of abusive conditions, e.g. high currents due to capacitive inrushes, this figure reduces considerably. Pickering will be pleased to perform life testing with any particular load condition.

**Note<sup>2</sup> Capacitance across open switch**

The capacitance across the open switch was measured with other connections guarded.

**Note<sup>3</sup> Capacitance values**

The value will depend upon on the mode of connection/guarding of unused terminals. Please contact technical sales for details.

**Internal Mu-metal Magnetic Screen**

The Series 114 relays are fitted with an internal mu-metal magnetic screen which permits side-by-side stacking on 0.25 inches pitch for Form A devices.

**Help**

If you need any technical advice or other help, for example, any special tests that you would like carried out, please do not hesitate to contact our Technical Sales Department. We will always be pleased to discuss Pickering relays with you. email: techsales@pickeringrelay.com

Pickering Electronics Limited  
Stephenson Road  
Clacton-on-Sea  
CO15 4NL  
England

email: sales@pickeringrelay.com  
Tel. (UK) 01255 428141  
(International) +44 1255 428141  
Fax. (UK) 01255 475058  
(International) +44 1255 475058



ISO9001 Manufacture of  
Reed Relays FM 29036

**Pin Configuration and Dimensional Data**

Dimensions in Inches (Millimeters in brackets)

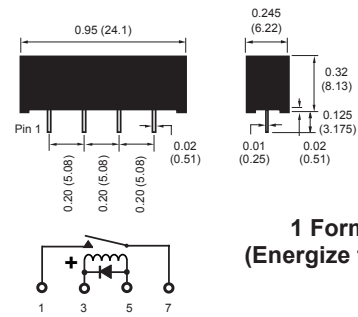

**1 Form A  
(Energize to make)**

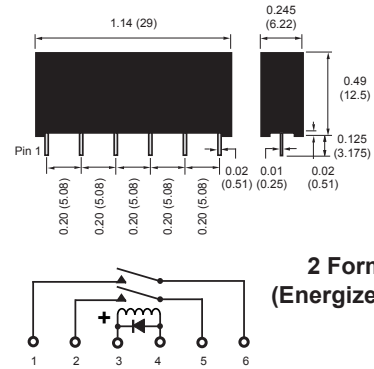

**2 Form A  
(Energize to make)**

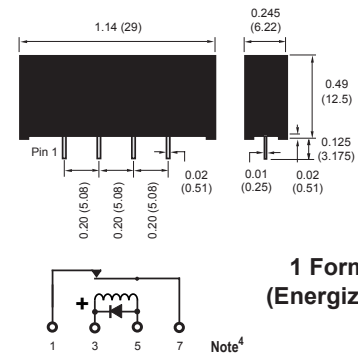

**1 Form B  
(Energize to break)**

**Important:** Where the optional internal diode is fitted or for all Form B types, the correct coil polarity must be observed, as shown by the + symbol on the schematics.

**Note<sup>4</sup>:** Due to the presence of an internal biasing magnet, Form B relays have a higher level of magnetic interaction than Form A types. A space of 0.4 inches minimum should therefore be left between adjacent parts.

**3D Models:** Interactive models of the complete range of Pickering relay products can be downloaded from the web site.

**Order Code**

**114 - 1 - A - 5 / 1 D**

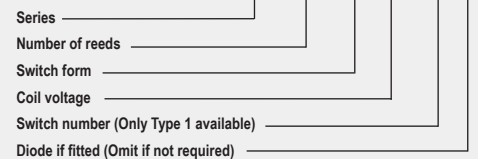

**Please ask us for a FREE evaluation sample.**