

General Purpose Reed Relays

Dry and Mercury wetted

Features

- Encapsulated in a plastic package with internal mu-metal magnetic screen
- Wide range of switch configurations
- Dry and mercury wetted switches are available with the same pin configuration and footprint (see "A useful tip" below)
- 5, 12 or 24 Volt coils with or without internal diode

These ranges of reed relays are available with both dry and mercury wetted switches. They are available with 5, 12 and 24 volts coils, a particularly useful feature of the 5 volt dry devices is their ability to be driven directly from TTL, the coil requiring only 10mA of drive current. All units have an internal magnetic screen and can be supplied with built-in diode if required.

Standard coil voltages are 5, 12 and 24 volts. All relays are fitted with internal magnetic screen to avoid stray magnetic interaction between adjacent relays. Many special coil resistances are available, and relays can be designed to customers specific requirements. These Pickering relays fit straight onto P.C. boards with pins on the popular 0.1 inch grid. They are completely protected, being encapsulated in plastic cases. With these series you get the choice of three different dry reed switches and two mercury wetted switches in a range of configurations to cover all switching problems. See "Switch Ratings" in adjacent column.

The Series 80 and 85 are electrically similar ranges but with alternative pin configurations; these are shown overleaf. Their mercury wetted equivalents are prefixed 88 and 89 respectively.

A useful tip

If there is a chance that you might want to use mercury wetted relays instead of dry relays at a later date, for example to increase switch ratings, lay out the PCB initially as though for the mercury wetted type. This allows upgrading later without PCB changes. The mercury Series 88 and 89 have identical pin configurations to the dry Series 80 and 85.

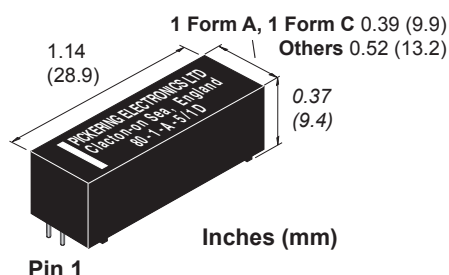
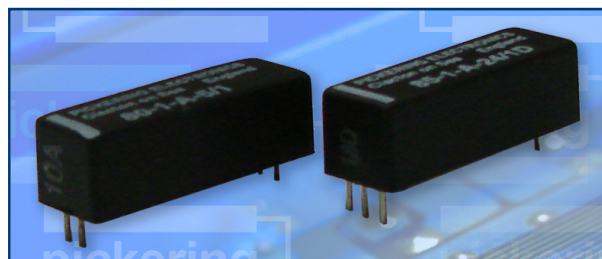

Switch Ratings - Dry Switches

- 1 Form A (energize to make), 10 watts at 200V
- 1 Form A (energize to make), 10 watts at 500V
- 1 Form B (energize to break), 10 watts at 200V
- 1 Form C (change-over), 3 watts at 200V
- 2 Form A (energize to make), 10 watts at 200V
- 2 Form C (change-over), 3 watts at 200V
- 3 Form A (energize to make), 10 watts at 200V

Switch Ratings - Mercury Wetted Switches

- 1 Form A (energize to make), 50 watts at 500V
- 1 Form B (energize to break), 50 watts at 500V
- 2 Form A (energize to make), 50 watts at 500V

Series 80, 85 switch ratings - The contact ratings for each switch type are shown below:

Switch No	Switch form	Power rating	Max. switch current	Max. carry current	Max. switching volts	Life expectancy ops typical (see Note 1 below)	Special features
1	A or B	10 W	0.5 A	1.2 A	200	10E8	General purpose
5	A	10 W	0.5 A	1.2 A	500	10E8	1000V stand-off
7	C	3 W	0.25 A	1.2 A	200	10E7	Change over

Series 80, 85 Coil data and type numbers

Device type	Type Number Series 80	Type Number Series 85	Coil (V)	Coil resistance	Max. contact resistance (initial)
1 Form A (energize to make) General Purpose Switch No. 1	80-1-A-5/1D	85-1-A-5/1D	5	500 Ω	0.15 Ω
	80-1-A-12/1D	85-1-A-12/1D	12	1000 Ω	
	80-1-A-24/1D	85-1-A-24/1D	24	3000 Ω	
1 Form A (energize to make) HV Switch No. 5 Note: Special Pin Configuration	80-1-A-5/5D	Not Available	5	500 Ω	0.15 Ω
	80-1-A-12/5D		12	1000 Ω	
	80-1-A-24/5D		24	3000 Ω	
1 Form B (energize to make) General Purpose Switch No. 1	80-1-B-5/1D	85-1-B-5/1D	5	1000 Ω	0.15 Ω
	80-1-B-12/1D	85-1-B-12/1D	12	3000 Ω	
	80-1-B-24/1D	85-1-B-24/1D	24	3000 Ω	
1 Form C (change-over) Switch No. 7	80-1-C-5/7D	85-1-C-5/7D	5	500 Ω	0.20 Ω
	80-1-C-12/7D	85-1-C-12/7D	12	1000 Ω	
	80-1-C-24/7D	85-1-C-24/7D	24	3000 Ω	
2 Form A (energize to make) General Purpose Switch No. 1	80-2-A-5/1D	85-2-A-5/1D	5	500 Ω	0.15 Ω
	80-2-A-12/1D	85-2-A-12/1D	12	1000 Ω	
	80-2-A-24/1D	85-2-A-24/1D	24	3000 Ω	
2 Form C (change-over) Switch No. 7	80-2-C-5/7D	85-2-C-5/7D	5	375 Ω	0.20 Ω
	80-2-C-12/7D	85-2-C-12/7D	12	1000 Ω	
	80-2-C-24/7D	85-2-C-24/7D	24	3000 Ω	
3 Form A (energize to make) General Purpose Switch No. 1	80-3-A-5/1D	Not Available	5	375 Ω	0.15 Ω
	80-3-A-12/1D			1000 Ω	
	80-3-A-24/1D			3000 Ω	

When an internal diode is required, the suffix D is added to the part number as shown in the table.

Mercury Reed: Series 88, 89 switch ratings - The contact ratings for each switch type are shown below:

Switch No	Switch form	Power rating	Max. switch current	Max. carry current	Max. switching volts	Life expectancy ops typical (see Note 1 below)	Special Features
1	A	50 W	2 A	3 A	500	10E8	Standard Mercury

Mercury Relay: Series 88, 89 Coil data and type numbers

Device type	Type Number Series 88	Type Number Series 89	Coil (V)	Coil resistance	Max. contact resistance (initial)
1 Form A (energize to make) Switch No. 1	88-1-A-5/1D	89-1-A-5/1D	5	140 Ω	0.07 Ω
	88-1-A-12/1D	89-1-A-12/1D	12	750 Ω	
	88-1-A-24/1D	89-1-A-24/1D	24	2000 Ω	
1 Form B (energize to break) Switch No. 1	88-1-B-5/1D	89-1-B-5/1D	5	90 Ω	0.07 Ω
	88-1-B-12/1D	89-1-B-12/1D	12	430 Ω	
	88-1-B-24/1D	89-1-B-24/1D	24	1750 Ω	
2 Form A (energize to make) Switch No. 1	88-2-A-5/1D	89-2-A-5/1D	5	90 Ω	0.05 Ω
	88-2-A-12/1D	89-2-A-12/1D	12	430 Ω	
	88-2-A-24/1D	89-2-A-24/1D	24	1750 Ω	

When an internal diode is required, the suffix D is added to the part number as shown in the table.

Note! Life expectancy

The life of a reed relay depends upon the switch load and end of life criteria. For example, for an 'end of life' contact resistance specification of 1 Ω, switching low loads (10 V at 10 mA resistive) or when 'cold' switching, typical life is approx 1 x 10⁸ ops. At the maximum load (resistive), typical life is 1 x 10⁷ ops. In the event of abusive conditions, e.g. high currents due to capacitive inrushes, this figure reduces considerably. Pickering will be pleased to perform life testing with any particular load condition.

Main contact:

UK Headquarters: email: sales@pickeringrelay.com | Tel. +44 1255 428141

Worldwide contacts:

USA: email: ussales@pickeringtest.com | Tel. +1 781 897 1710

Germany: email: desales@pickeringtest.com | Tel. +49 89 125 953 160

China: email: johnson@tomtech.cn | Tel. 0755 8374 5452

For a full list of agents and representatives visit: pickeringrelay.com/agents



ISO9001 Manufacture of Reed Relays FM 29036



Dimensional Data

Dimensions in Inches (Millimeters in brackets)

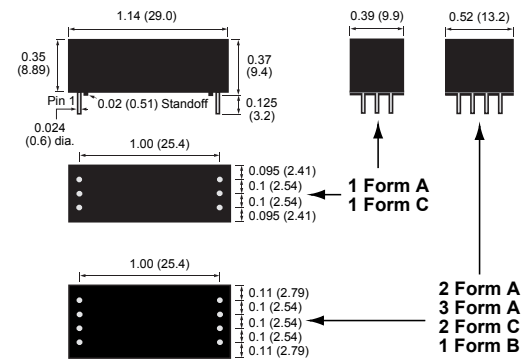

Pin Configurations

Schematics are shown from UNDERNEATH the relay.

Series 80 & 88

Orientation Bar printed on top face at this end

Mercury Series 88 this way up

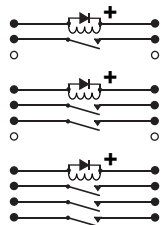

Series 85 & 89

Orientation Bar printed on top face at this end

Mercury Series 89 this way up

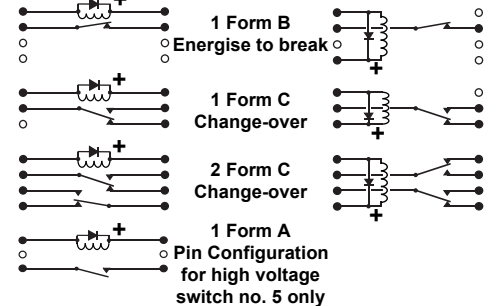
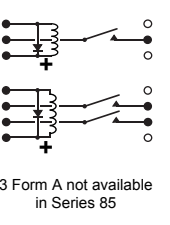

Important: Where the optional internal diode is fitted or for all Form B types, the correct coil polarity must be observed, as shown by the + symbol on the schematics.

3D Models: Interactive models of the complete range of Pickering relay products can be downloaded from the web site.

Mercury Relays

Mercury wetted relays should be mounted vertically in the direction of the arrow printed on the package.

Order Code

80 - 1 - A - 5 / 2 D

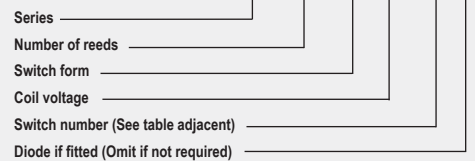

Help

If you need any technical advice or other help, for example, any special tests that you would like carried out, please do not hesitate to contact our Technical Sales Department. We will always be pleased to discuss Pickering relays with you. email: techsales@pickeringrelay.com

Please ask us for a FREE evaluation sample.



pickeringrelay.com